

BACKHOE

Installation, Operation and Maintenance Manual

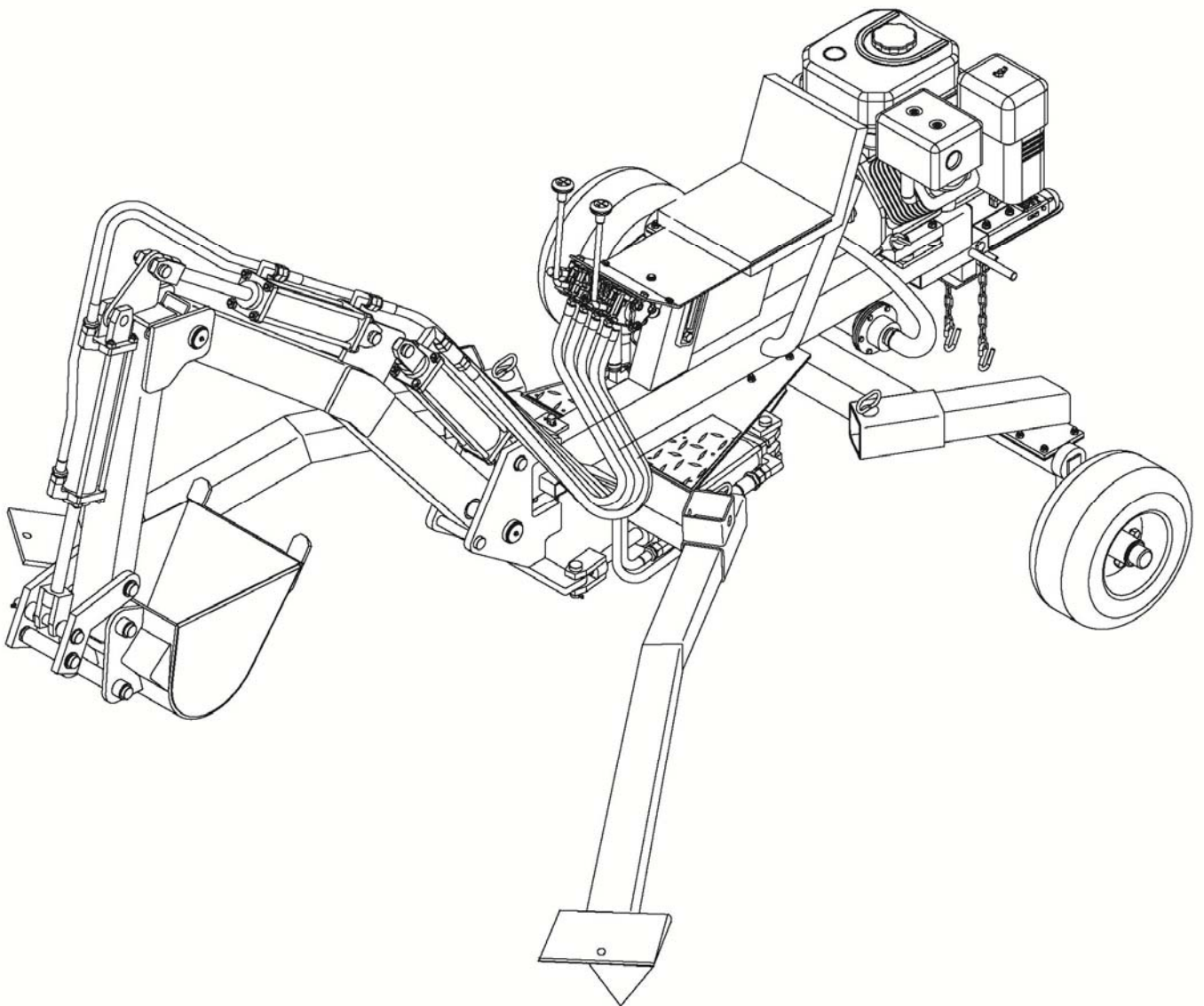

Backhoe: Digs trenches in earth up to 7ft. deep.

Import-Rules for safe Operation

- 1) Read the Owner's Manual completely before attempting to use this backhoe.
- 2) Do not allow anyone to operate your backhoe who has not read the Operator's Manual or has not been instructed on the safe operation of the backhoe.
- 3) Never allow children or untrained adults to operate this machine.
- 4) Never allow anyone to ride on the backhoe while towing.
- 5) Never transport cargo on the backhoe.
- 6) High fluid pressures are developed in hydraulic backhoes. Pressurized fluid escaping through a pin hole opening can puncture skin and cause severe blood poisoning. Therefore, the following instructions should be followed at all times.
 - (a) Do not operate the unit with frayed, kinked, cracked or damaged hoses, fitting, or tubing.
 - (b) Stop the engine and relieve hydraulic system pressure before leaving the backhoe unattended or servicing fittings, hoses, tubing, or other system components.
 - (c) Do not adjust the pressure settings of the pump or control valve.
 - (d) Do not check for leaks with your hand. Leaks can be located by passing cardboard or wood over the suspected area. Look for discoloration. If injured by escaping fluid, see a doctor at once. Serious infection or reaction can develop if proper medical treatment is not administered immediately.
- 7) Keep the operator zone and adjacent area clear for safe trenching.

Use extreme caution when operating near structures, utility line, or when other workers are present. Call utilities before you dig .Do not straddle trench with backhoe .Move backhoe backward and away from the trench as you dig.
- 8) If your backhoe is intended for use near any unimproved forest, brush, or grass covered land, the engine exhaust should be equipped with a spark arrestor. Make sure you comply with applicable local, state, and federal codes. Take appropriate fire-fighting equipment with you.
- 9) Backhoes should be only used for trenching. Do not use for other purpose.
- 10) Never alter the backhoe or any part of its manufactured design.

Preparation

- 1) Contact municipalities and utilities to locate buried lines before digging. Do not dig until you have fully investigated the area. Use extreme caution when overhead or buried utility lines are present.
- 2) Be thoroughly familiar with all controls and with the proper use of the equipment.
 - (a) Always wear safety shoes or heavy boots
 - (b) Always wear safety glasses or goggles and approved safety headgear when operating the machine.
 - (c) Never wear jewelry or loose fitting clothing that might become entangled in moving or rotating parts of the machine.
 - (d) Always wear protective hearing devices when operating the backhoe. Continued exposure to loud machinery can cause hearing loss.

- 3) Make sure the backhoe is on a level surface with no more than 10°incline. Block the machine as required to prevent unintended movement. Do not operate near soft-shouldered inclines that may not provide adequate support.
- 4) Always operate the backhoe from the operator seat with hands positioned near valve controls and feet flat on the area provided.
- 5) Handle fuel with care; it is highly flammable.
 - (a) Use an approved fuel container.
 - (b) Never add fuel to a running or hot engine.
 - (c) Fill fuel tank outdoors with extreme care. Never fill fuel tank indoors.
 - (d) Replace gasoline cap securely and clean up spilled fuel.
- 6) Only use the backhoe in daylight or adequate artificial light.

Unpacking

Closely inspect all contents in the shipping carton.

Due to the weight of the backhoe, two people are needed to unpack. The following procedure prepares the backhoe for towing.

Assembly Instructions

STEP 1: Assemble the Wheel Leg.

- a. Insert the wheel leg into the Backhoe Frame, insert the Safety pin (#42) then lock with R Pin (#41).

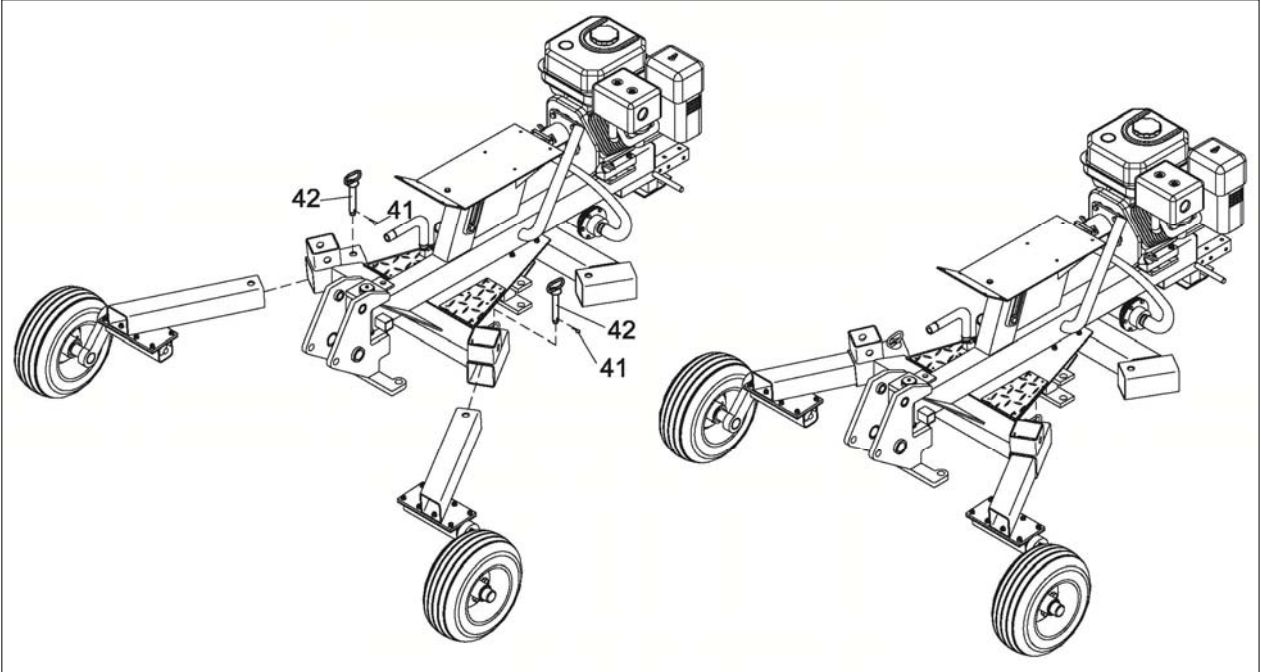

STEP 2: Assemble the Arm.

- a. Connect the Short Arm assembly with Long Arm Assembly by using Axis Pin (#86), Washer $\text{\O}38$ (#114) and lock with Cotter Pin (#84).
- b. Connect the cylinder on the long boom to the short boom by using Short Pin $\text{\O}30 \times 97$ (#63), Flat Washer $\text{\O}24$ (#115), and lock with Cotter Pin $\text{\O}4 \times 50$ (#55).

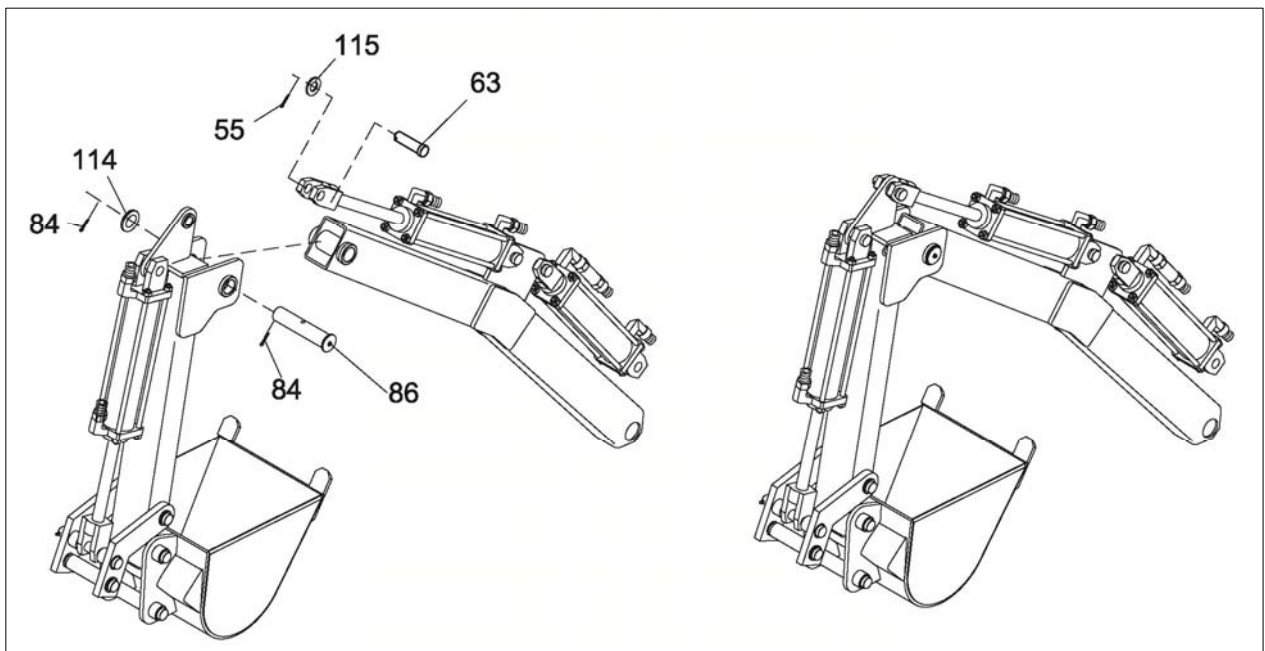

- c. Attach the Long Arm to the Swivel Bracket Assembly by using Axis Pin(#86), Washer Ø38 (#114) and lock with Cotter Pin (#84).
- d. Put the Arm to the Backhoe Frame by using Long PinØ30x170 (#85),Flat Washer Ø24 (#115), and lock with Cotter Pin Ø4x50 (#55).

Note: The Pin (#85) is a safety Pin. Remove it before using the machine and insert it when you want remove.

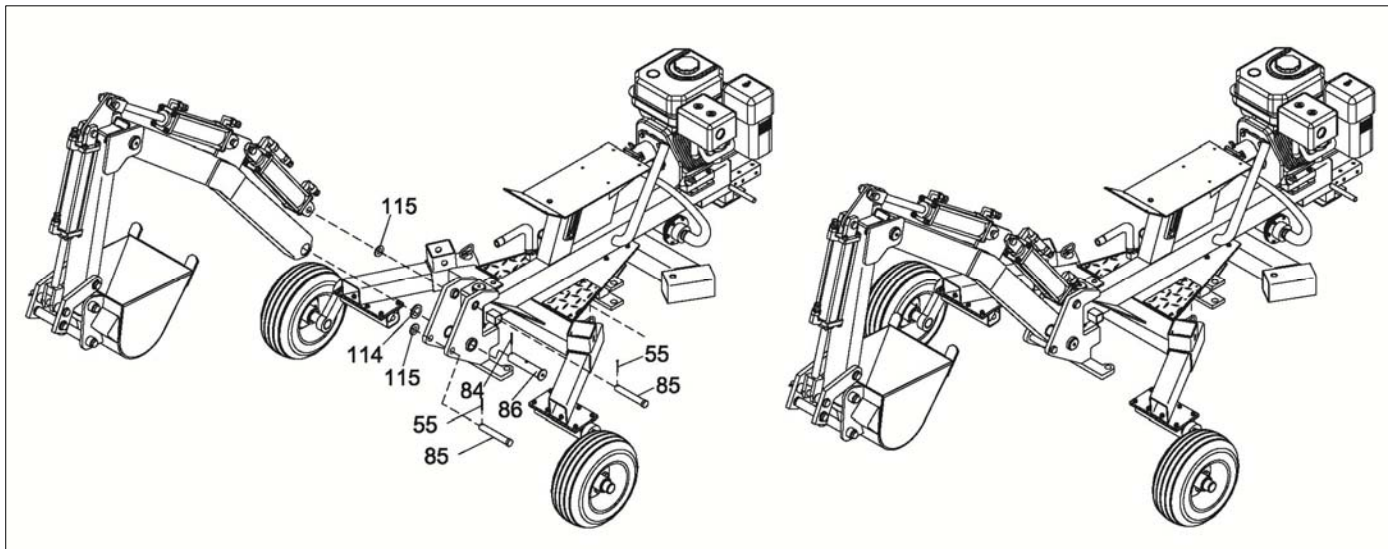

STEP 3: Assemble the Swivel Cylinder.

- a. Attach the Cylinder (#59) to the Swivel Cylinder Base by using the Pin Ø30x124 (#54),Flat Washer Ø24 (#115),then lock with Cotter Pin Ø4x50(#55).
- b. Connect the Cylinder (#59) to the Swivel Bracket Assembly by using Short PinØ30x97 (#63),Flat Washer Ø24 (#115),then lock with Cotter Pin Ø4x50 (#55).

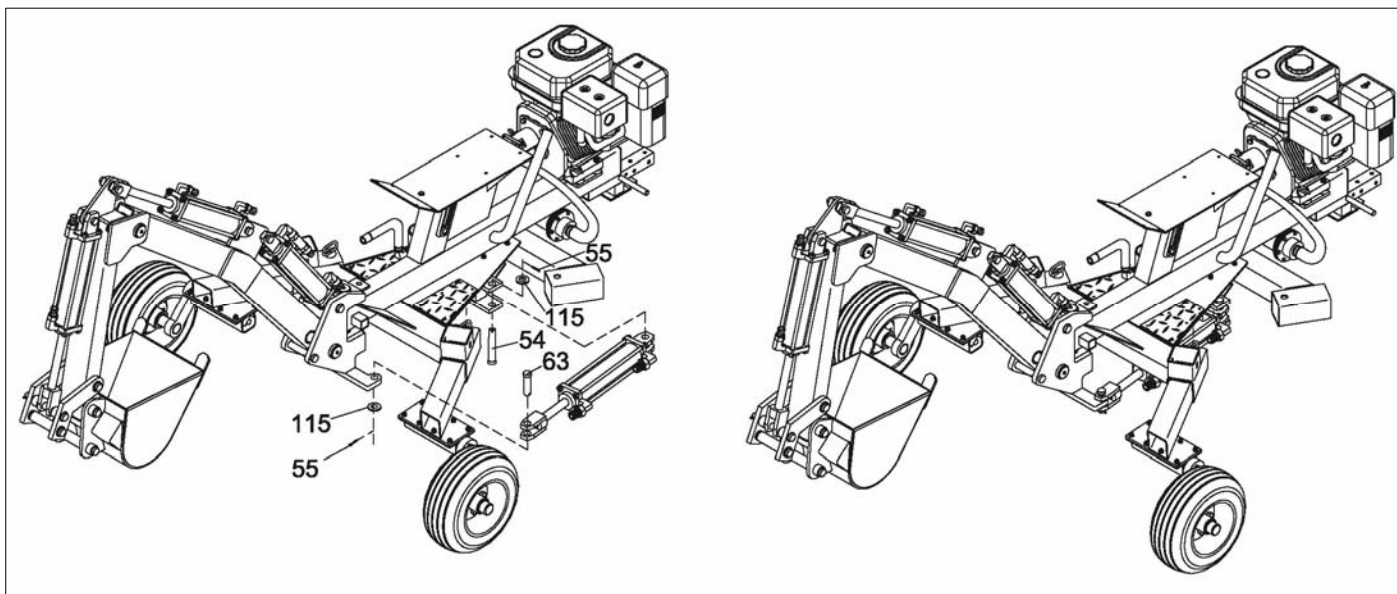

STEP 4: Assemble the Seat, Control Valve and Coupler

- a. Attach the Seat (#16) to the Frame by using Hex Bolt 5-16"-3/4" (#68), Flat Washer Ø8 (#21), Lock Washer Ø8 (#22).
- b. Attach the assembled of control valve to the valve plate by using Bolt M10x20 (#81) and Nylon Lock Nut M10 (#19).
- c. Insert the Outrigger (#78) to the square tube, then insert the Pin (#42) and lock with R Pin Ø3x55 (#41).
- d. Insert the Fixed Pin Ø19x50 (#89) into the Backhoe Frame, lock with R pin (#41).
- e. Attach the coupler (#37) to the tow bar by using Hex Bolt M12x80 (#38), Flat Washer Ø12 (#39) and Nylon Lock Nut M12 (#40).
- f. Attach the two chains (#103) to the tow bar by using Hex Bolt M12x90 (#107), Flat Washer Ø12 (#39), Nylon Lock Nut M12 (#40) and Thick Flat Washer Ø12 (#67).

Note: The Pin (#89) is a safety Pin. Remove it before using the machine and insert it when you want remove.

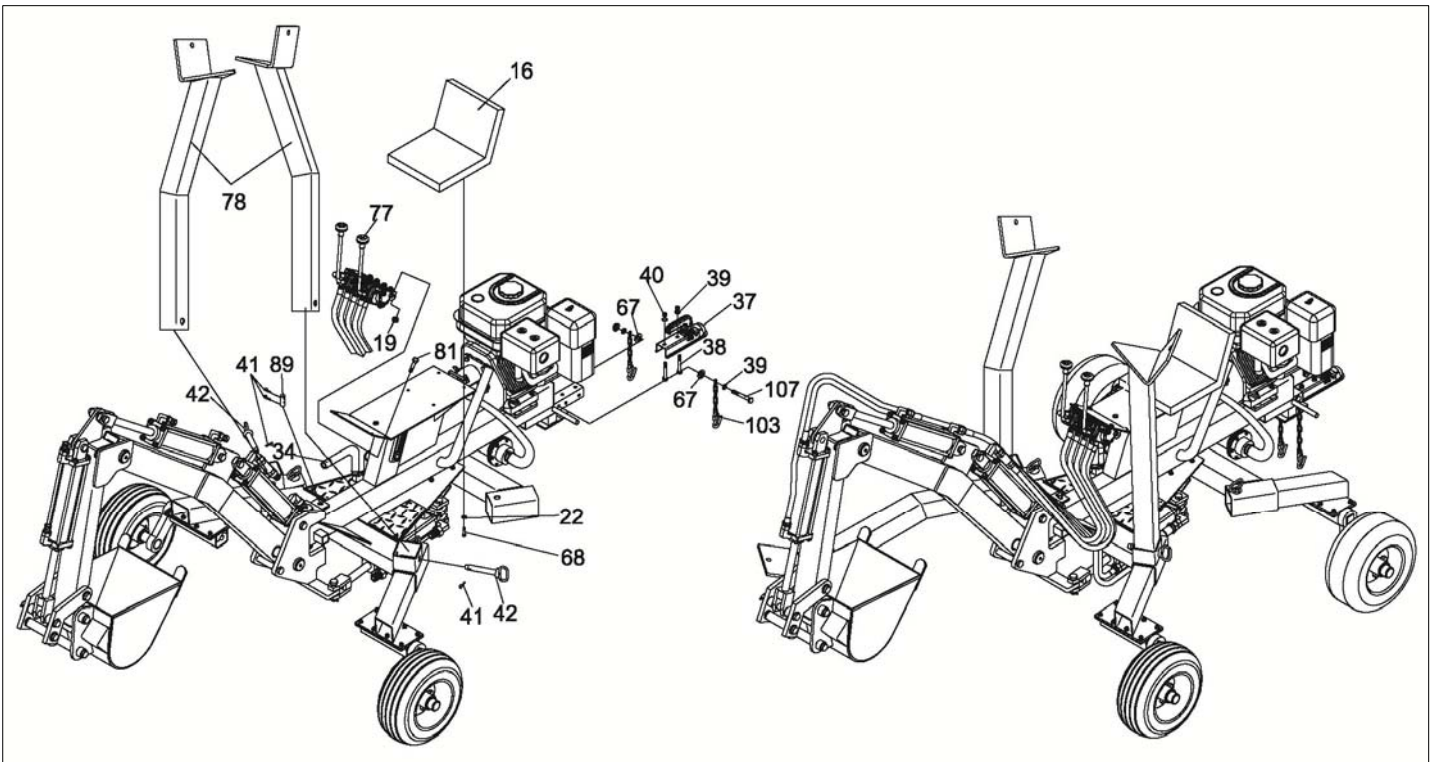

STEP 5: Connect the Hydraulic Hose.

- a. Attach the Hydraulic hose 1A to the Connector of Valve 1A (as the label).
- b. Attach the Hydraulic hose 1B to the Connector of Valve 1B (as the label).
- c. Assemble others as above.

Note: 1. HYDRAULIC HOSE LINE: Attach the Hydraulic Hose 1A & 1B at the right side of Arm, use the Clamp Clip to lock it. Attach other Hydraulic Hoses at the left side of Arm, use the Clamp Clip to lock the hydraulic hose of 2A & 2B.

2. FUELING METHOD: first time to fill the oil to between red and black lines at oil window, starting the engine, operating the control valve handles to make each Hydraulic cylinder stroke stretch out and draw back one time, let the oil fill full the cylinders, then to refill the oil to between red and black lines at oil window.

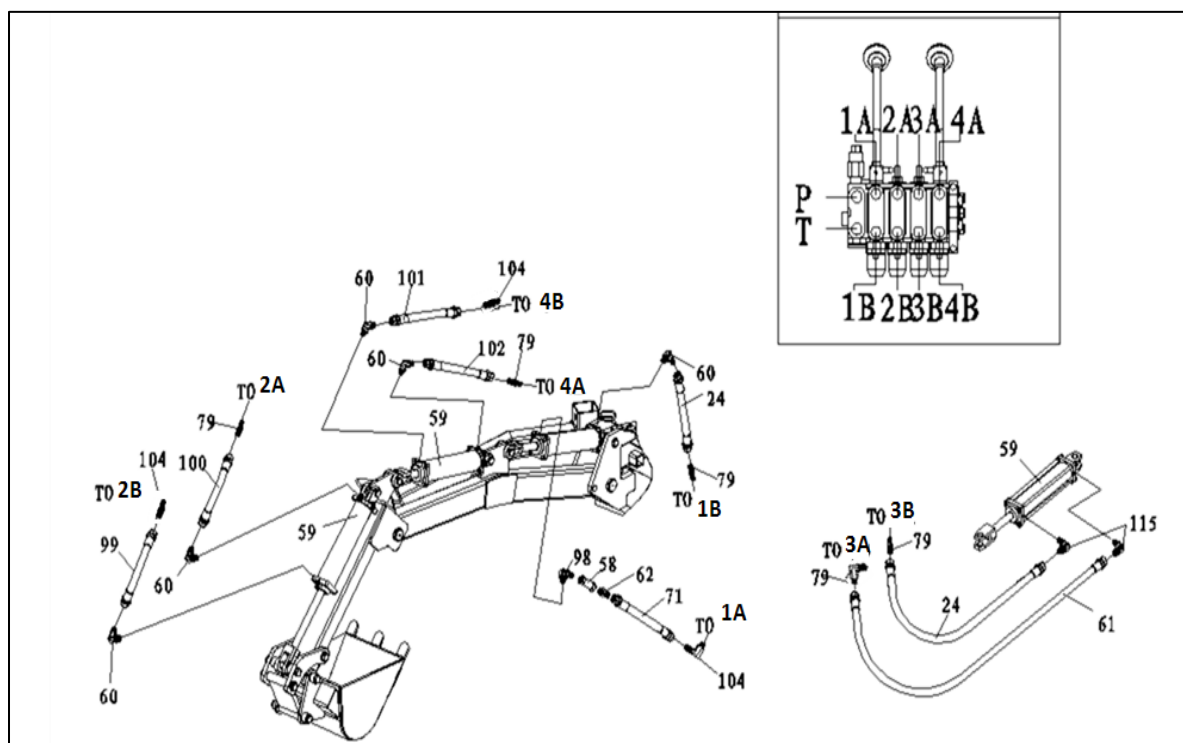
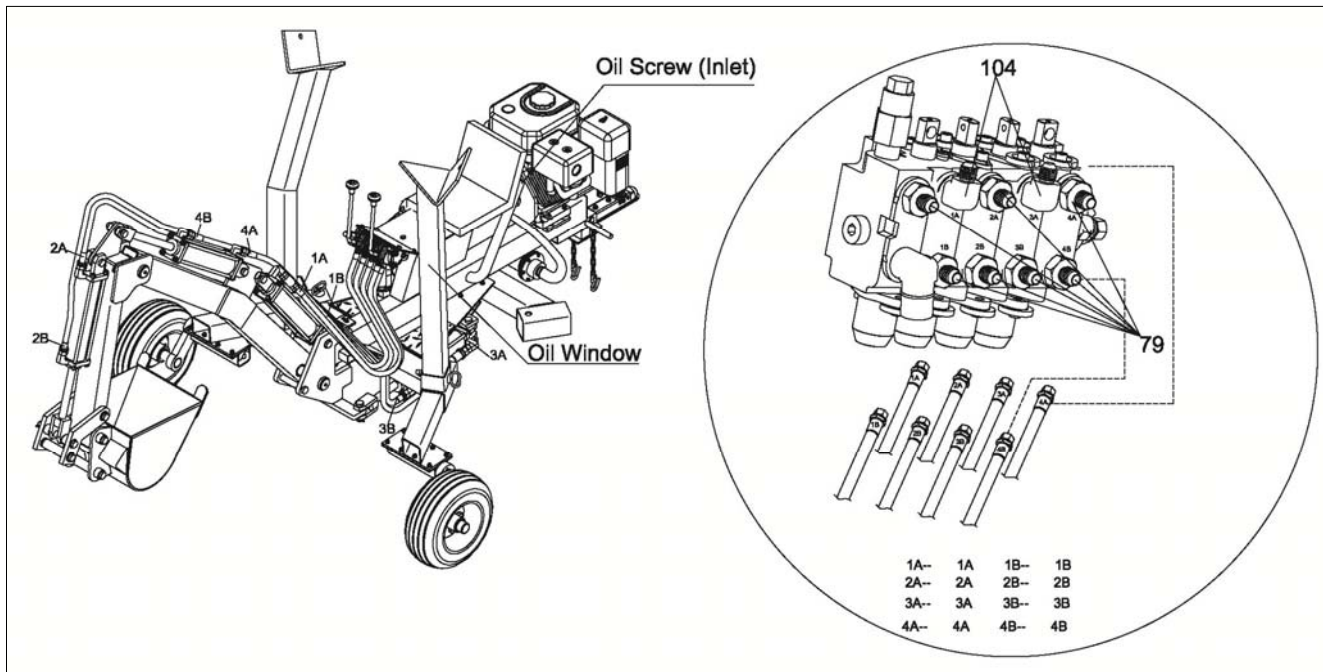

24	Hydraulic Hose 700	2	100	Hydraulic Hose 2550	1
61	Hydraulic Hose 1100	1	101	Hydraulic Hose 2100	1
71	Hydraulic Hose 850	1	102	Hydraulic Hose 1700	1
99	Hydraulic Hose 2850	1			

Hydraulic Oil

Add the Hydraulic Oil

- 1) There is a Oil Screw behind the seat, screw off the Oil Screw. Fill the tank slowly with 10wt hydraulic oil while checking the oil sight gauge. Once the tank is full, stop to add hydraulic oil and screw the Oil Screw back on the tank.

When the first time to add Hydraulic Oil, the oil should between the black and red line of Oil window. Then start the engine, manipulate the control handle, make every cylinder stretch out and draw back for one time, let the cylinder with full oil. Then, add oil between the black and red line of Oil window for the second time.

- 2) Start the engine and run at slow idle
- 3) Push and pull lever#4 back and forth 6-8 times to remove air from the hydraulic lines. While moving the lever, watch the clear hose on the right side under the control levers. If there is a steam of bubbles, that is normal. If a foamy solution is moving through the tube, air is still in the oil. Keep pushing a pulling the lever until the stream of bubbles appears. After lever#4 is completed, do the same with lever#3, lever#2, and lever#1. Watch the oil levers. Once all four levers are done, fill the tank up to the black line on the oil sight gauge in the hydraulic tank. The whole hydraulic system contains about 3 gallons of oil.
- 4) Shut off the engine, screw the Oil Screw back on the tank.

Changing the Hydraulic Oil

- 1) Remove the Inlet Filter on the bottom part of the frame below the engine. Once the old hydraulic oil is removed, tighten the Filter back onto the tank. Be sure to properly dispose of the old hydraulic oil.
- 2) Screw off the Oil Screw behind the seat. Fill the tank with 10wt hydraulic oil. While checking the oil level on the sight gauge. Screw the Oil Screw back onto the tank.
- 3) Remove the up-down travel pin and the side-to-side travel pin.
- 4) Start the engine and run at slow idle
- 5) Push and pull lever#4 back and forth 6-8 times to remove air from the hydraulic lines. While moving the lever, watch the clear hose on the right side under the control levers. If there is a steam of bubbles, that is normal. If a foamy solution is moving through the tube, air is still in the oil. Keep pushing a pulling the lever until the stream of bubbles appears. After lever#4 is completed, do the same with lever#3, lever#2, and lever#1. Watch the oil levers. Once all four levers are done, fill the tank up to the black line on the oil sight gauge in the hydraulic tank. The whole hydraulic system contains about 2-1/2 gallons of oil. Shut off the engine,
- 6) Reattach the up-down and side-to-side traveling pins.

Towing the Backhoe

- 1) Always obey all state and local regulations when towing the backhoe on public roads or highways.
- 2) Never allow anyone to sit or ride on your backhoe. They could easily fall off and be injured.
- 3) The backhoe is not a trailer. Do not carry any cargo on the backhoe. It can fall off and endanger you and other drivers.
- 4) Be certain the backhoe is securely attached to the towing vehicle before towing .The safety chains should be hooked onto the vehicle with sufficient slack for turning allowance. Always secure trailer hitch with locking bolt.
- 5) Be sure to secure the boom up and centered with the up-down and side-to-side travel pins provided. With the engine off, slightly lower the boom to lock it in place and prevent it from swinging. Also, curl the bucket and arm in to achieve a compact towing configuration.
- 6) Be sure the outriggers are secured in the vertical position before towing. Do not tow with outriggers down.
- 7) Be aware of the added length of the backhoe when you are towing it behind a vehicle. Be careful not to jack-knife your backhoe when backing the vehicle.
- 8) Towing speed should be according to driving conditions. Use a “Slow Moving Vehicle” sign when driving on roads .Take extra care when driving on rough terrain.
- 9) Disconnect the backhoe from the towing vehicle before using backhoe.
- 10) Grease wheel bearings annually, or after long trips, to extend the life of your bearings.

Digging Mode and Towing Mode

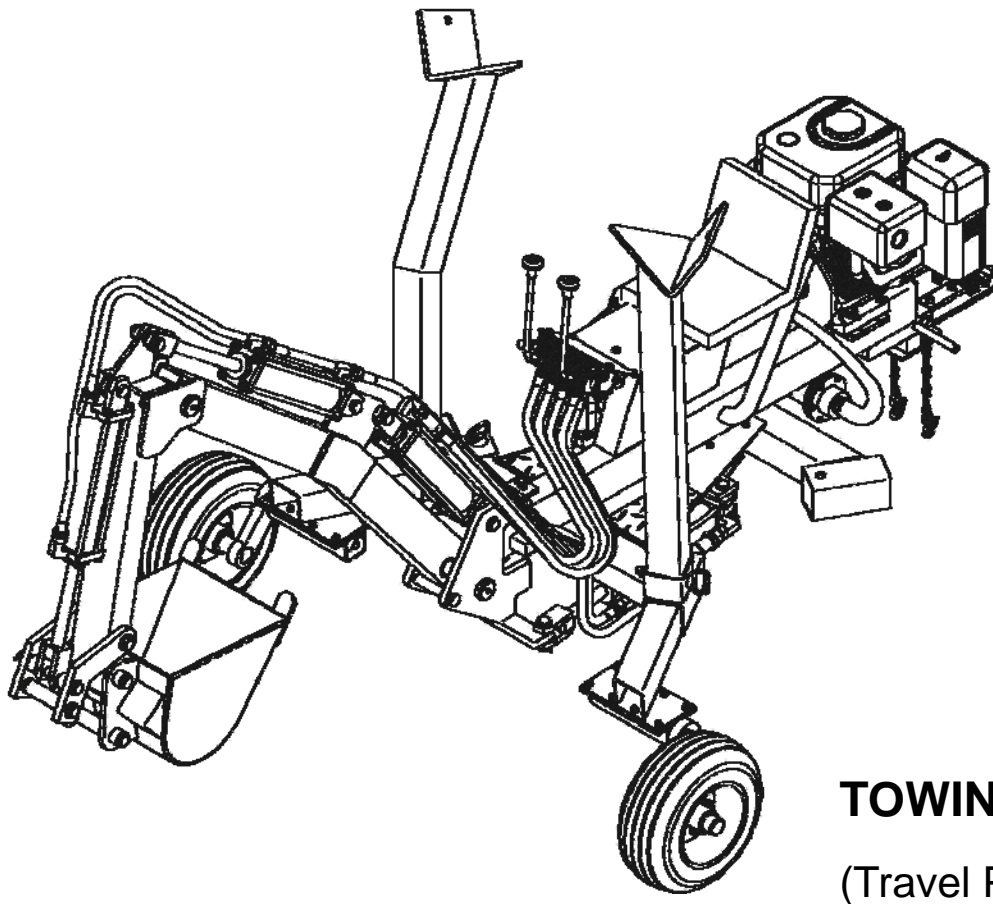
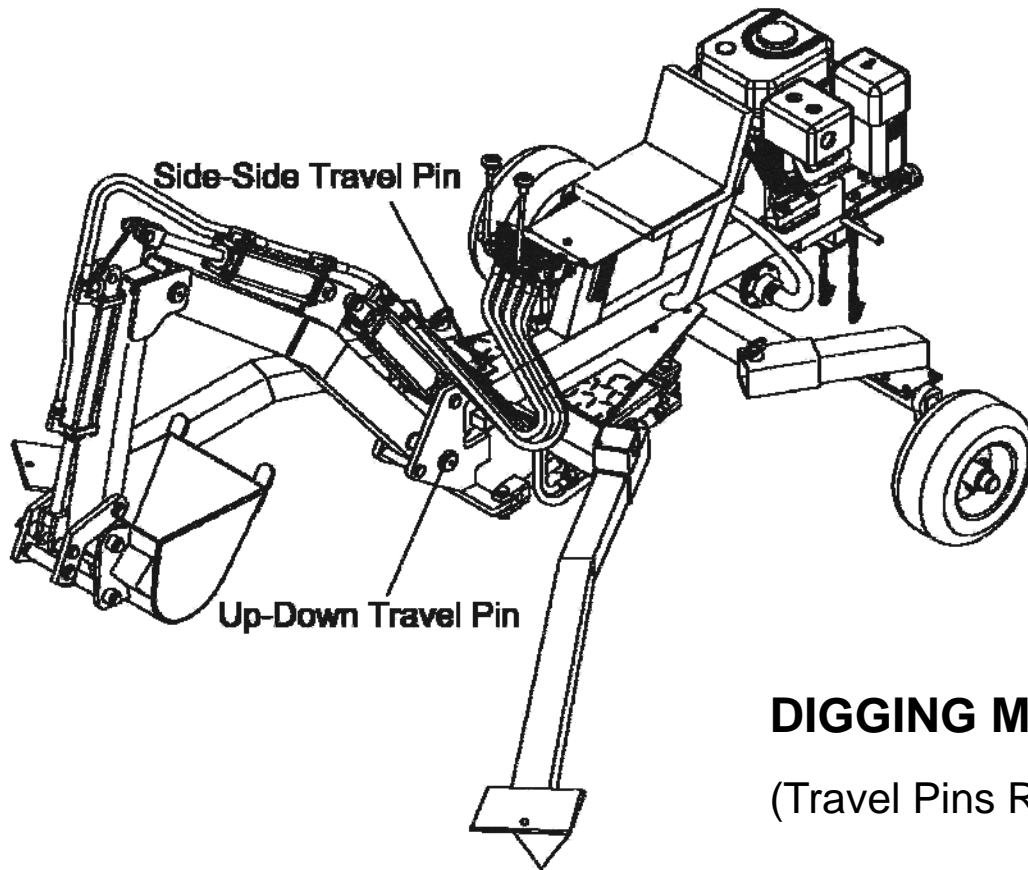

Digging Mode

After towing the backhoe to the desired location, follow these set-up instructions. Do not sit on the backhoe while setting it up.

- 1) Remove outriggers from vertical and set them aside. This reduces weight. Outriggers are heavy, use cart when lifting.
- 2) Be sure to remove the up-down and side-to side travel pins. Keep these two pins to re-insert for towing.

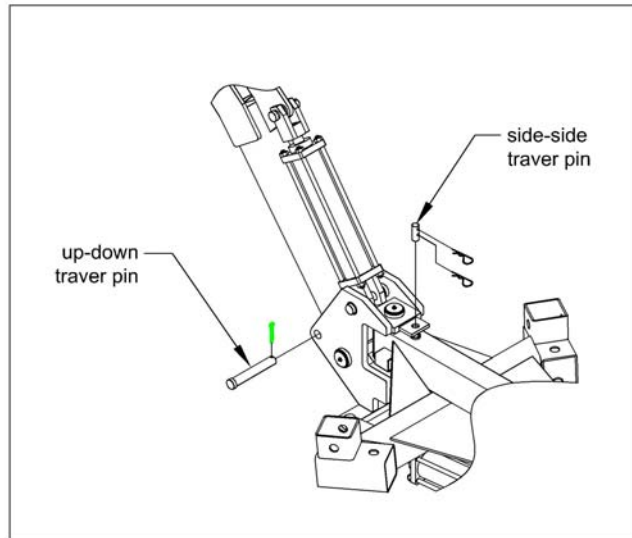
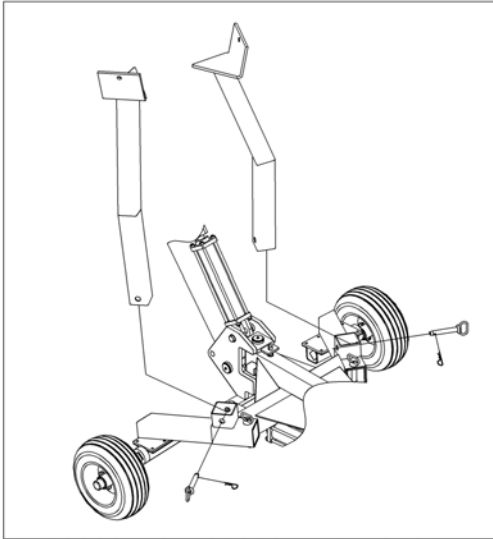

Disconnect the backhoe from the towing vehicle.

- 3) Pull lever #2 towards left until wheels elevate off the ground 4-5 inches.
- 4) Remove wheels. Looking at until as if you were sitting in operator seat, put outrigger in front left slot, secure with pin and put front wheel by rear right slot. Install other outrigger in front right slot, secure with pin and put front right wheel by rear left slot. Lower wheels by pushing lever #2 right.
- 5) Position bucket next to the right side outrigger. Elevate the right side of the unit by pulling lever #2 left until right side balances enough to install back-right wheel into slot. The right outrigger should be about 2feet of the ground .Install back right wheel into slot and secure with pin.
- 6) Lower right side of until by pushing lever #2 right to wh the ground and the flat part of the bucket is flush to the ground .Insert the back-left wheel into the slot and secure with pin. If needed, move bucket next to the left outrigger and elevate the left side to allow wheel to be inserted in to slot. Make sure all pins are secure.

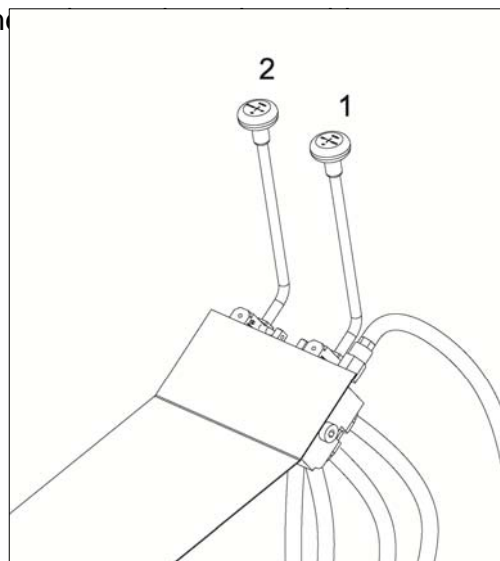

The backhoe is now in digging mode. Read the entire manual before attempting to operate the backhoe. Like any industrial tool, proper training and preparation are needed to safely and efficiently operate the backhoe.

Maintenance and Storage

Before performing any maintenance on the backhoe, it must be placed in maintenance mode.

- (a) Turn off engine
- (b) Move the control valves handle back and forth with the engine OFF to relieve hydraulic pressure
- (c) Rest boom on the ground.
- (d) Unplug spark plug wire from spark plug
- 1) Clean debris from the engine cylinder, cylinder head fins, blower housing rotating screen, and muffler areas. If the engine is equipped with a spark arrestor muffler, clean and inspect it regularly. Replace if damaged. Clear debris from movable parts, but only after the power source is shut off.
- 2) Check to be sure all nuts and bolts are tight to assure the equipment is in safe working condition.
- 3) Inspect all hoses and fitting for wear and leaks. Perform all inspections and replace all damaged and worn parts prior to starting the engine.
- 4) Be sure all guards, shields, and safety features are in place.
- 5) Inspect the suction filter.

What to check	When to check	What to do
Tires	Each Trip	Check Pressure. The pressure rating is listed on the tire
Hoses	Each Use	Inspect for wear and leaks. Replace all worn or damaged hoses before starting engine.
Hydraulic Fittings	Each Use	Inspect for wear and leaks. Replace all damaged fittings before starting engine.
Nuts and Bolts	Each Use	Check for loose bolts
Hydraulic Oil	Each Use	Add oil as needed. Replace annually or when it appears dark or cloudy.
Boom Pins	Each Use	Grease
Suction Filter	Annually	Replace
Wheel Bearings	Annually	Repack with grease.

Storage

Before you store your backhoe, make sure you do the following.

- 1) Remove gasoline from the engine or add fuel stabilizer to the gasoline to prevent gumming.
- 2) If adding stabilizer, run engine for five minutes.
- 3) Turn engine OFF.
- 4) Move the control valve handles back and forth with the engine OFF to relieve hydraulic pressure.
- 5) Remove the spark plug
- 6) Pour one teaspoon of engine oil into spark plug hole. Cover spark plug hole with a rag and turn engine over several times to lubricate the cylinder.
- 7) Replace spark plug.
- 8) Never store the backhoe where fumes might reach an open flame or spark. Allow the engine to cool before storing in any enclosure.

Troubleshooting

PROBLEM

Cylinder rod will not move	SOLUTION:A,C,E,O,Q,R,U,V
Slow cylinder shaft speed when extending or retracting	SOLUTION:E,J,L,O,R,S,T,W
Backhoe will not dig or digs extremely slowly	SOLUTION:D,H,J,M,R,S,T,W
Engine stalls during digging motion	SOLUTION:K,N,P
Engine will not turn or stalls under low load conditions	SOLUTION:B,F,K,Q,V
Leaking pump shaft seal	SOLUTION:A,B,E,G,I
CAUSE	SOLUTION
A-Broken driveshaft on pump	Return pump for authorized repair
B-Engine/ pump misalignment	Correct the engine/pump alignment
C-Loose shaft coupling	Correct the engine/pump alignment
D-Small gear section damaged	Items D through H require repair of the pump by an authorized service center
E-Gear sections damaged	
F-Frozen or seized pump	
G-Poorly positioned shaft seal	
H-Pump check valve leaking	
I-Plugged oil breather	Make sure the reservoir is properly vented
J-Excessive pump inlet vacuum	Clean inlet hoses and free them of any leaks
K-Low horsepower/weak engine	Have engine serviced at an authorized service center
L-Slow engine speed	Have engine serviced at an authorized service center
M-Low relief valve setting	Adjust while using a pressure gauge and with assistance of a professional
N-High relief valve setting	Adjust while using a pressure gauge and with assistance of a professional
O-Damaged relief valve	Return directional valve for authorized repair
P-High unloading valve setting	Adjust while using a pressure gauge and with assistance of a professional
Q-Hydraulic lines blocked	Flush and clean the hydraulic system
R-Too little oil to the pump	Add oil to the reservoir
S-Air in the hydraulic oil	Clean reservoir and add oil
T-Control valve leaking internally	Return directional valve for authorized repair
U-Damaged control valve	Return directional value for authorized repair
V-Blocked control valve	Flush and clean the hydraulic system
W-Internally damaged cylinder	Return cylinder for authorized repair

Operation Instructions

- 1) Before starting this backhoe, review the “Rules for Safe Operation.” Failure to follow these rules may result in serious injury to the operator or bystanders. The machine owner should instruct all operators in safe backhoe operation. Call all utilities or a one-call service to mark utility lines.
- 2) Before digging with the backhoe, make sure backhoe is in digging mode.
- 3) Run your engine only in well ventilated areas. Carbon monoxide fumes are odorless and colorless. Inhaling these gases can cause carbon monoxide poisoning. Never leave the machine unattended with the engine running.
- 4) Never operate the machine when under the influence of alcohol, drugs, or medication.
- 5) Always operate the backhoe with all safety equipment in place and all controls properly adjusted for safety operation.
- 6) Always operate the backhoe at the manufacturers recommended speed. Always be ready to stop the engine and disengage the boom in case of emergency.
- 7) Always keep hands, feet, and all other body parts clear of moving parts.
- 8) Do not straddle or climb over the boom. Serious injury can result from a slip while straddling or climbing.
- 9) BE sure the terrain allows wheels and outriggers to make firm contact with ground.
- 10) Before digging, take the time to learn the control valves and the function each performs. Learn how they work in conjunction with each other. A description of what each control valve does is illustrated on the valve mounting plate Practice using the control valves before digging, it will make for safer and more efficient trenching.
- 11) Position bucket with teeth perpendicular to the ground.
- 12) Extend the arm out. Then, lower the boom until resistance is met. Do not make the outriggers leave the ground.
- 13) Curl the arm or bucket to scoop earth. Should either of these movements make the outriggers move, raise the boom slightly to make the outriggers dig in to provided support.
- 14) Once the digging motion is complete, completely curl the bucket. Raise rotate the boom to clear the trench.
- 15) Empty the bucket. Repeat steps 11-15 for each scoop.
- 16) Do not attempt to straddle the backhoe over a trench. It could fall into the excavation site and cause serious injury. Move backhoe backward and away from trench as you dig.
- 17) Do not refuel the engine until it has cooled for several minutes.

Moving the backhoe

WARNING! It is possible to move the backhoe under its own power when it is digging mode. This movement should be done with caution. Do not attempt these maneuvers until fully comfortable with the controls and only when the backhoe is away from hazards.

DO not attempt to straddle the backhoe over a trench. It could fall into the excavation site and cause serious injury. Move backhoe backward and away from trench as you dig.

Move Backward

- 1) Make sure backhoe is in digging mode.
- 2) Curl the arm in and lower the boom to rest bucket teeth into the ground. The bucket should rest in the center of the work area, two feet from the front of the backhoe frame.
- 3) Raise the until off its outriggers by lowering the boom.
- 4) Once the outriggers are clear of the ground, rotate the arm out.
- 5) This will cause the backhoe to move backward.
- 6) Raise the boom until weight is on the outriggers again.

Move Forward

- 1) Make sure backhoe is in digging mode.
- 2) Rotate the arm out and lower the boom to rest bucket teeth into the ground. The bucket should rest in the center of the work area.
- 3) Raise the until off its outriggers by lowering the boom.
- 4) Once the outriggers are clear of the ground, curl the arm in. This will cause the backhoe to move forward.
- 5) Raise the boom until weight is on the outriggers again.

Move Side to Side

- 1) Make sure backhoe is in digging mode.
- 2) Raise boom and swing boom to the side where the new work area is located.
- 3) Lower boom to rest bucket teeth into the ground and raise outriggers off the ground
- 4) Swing boom in the direction opposite the desired movement of the machine.
- 5) Once the unit is facing the new work area, raise the boom until weight is on the outriggers again.

Specification

- Bucket Size: 10"
- Engine Power: 9HP
- Engine Speed:3600 rpm
- Cylinder Working Pressure:16 Mpa
- Cylinder Diameter & Stroke: Ø63x300mm
- Cylinder Qty: 4pcs
- Bucket Swivel Degree:120°
- Max.Dig Depth: 2040mm
- Max.Dig Semidiameter:2560mm
- Max.Load Height:1400mm
- Coupler Size: 2" Ball for easy towing
- Oil Capacity:14.6L
- Wheel Size:16"

Parts List

PART#	DESCRIPTION	QTY	PART#	DESCRIPTION	QTY
1	Cotter Pin 4x30	2	41	R Pin Ø3x55	6
2	Slotted Nut M20x1.5	2	42	Safety Pin	4
3	Wheel Axle Cap	2	43	Flat Washer Ø6	6
4	Lug Bolt	8	44	Lock Washer Ø6	6
5	Wheel	2	45	Hex Bolt M6x20	6
6	Taper Roller Bearing	4	46	Hex Bolt M10X25	4
7	Flange	2	47	Inlet Filter	1
8	Oil Seal	2	48	Rubber Washer	1
9	Axle Assembly	2	49	Filter Fix Plate	1
10	Rubber Rod	8	50	Valve Return Oil Hose 370	1
11	Rubber Skateboard	8	51	Inlet Connector of Filter	1
12	Square Axle Base	2	52	Outlet Filter	1
13	Lock WasherØ10	24	53	Outlet Connector of Filter	1
14	Flat Washer Ø10	24	54	Pin Ø30X134	1
15	Hex Bolt M10x30	12	55	Cotter Pin Ø4x50	13
16	Seat	1	56	Swivel Cylinder Base	1
17	Engine	1	57	Hex Bolt M10x45	4
18	Wheel Frame Connector Tube (Right)	1	58	Single Throttling Valve	1
19	Nylon Lock Nut M10	27	59	Cylinder	4
20	Hex Bolt M8x30	4	60	Right Angle Connector I	5
21	Flat Washer Ø8	8	61	Hydraulic Hose 1100	1
22	Lock Washer Ø8	16	62	Connector of Throttling Valve	1
23	Hex Bolt M8x25	4	63	Short Pin Ø30x97	5
24	Hydraulic Hose 700	2	64	Hex Bolt M12x30	2
25	Nylon Lock Nut M8	4	65	Gauge	1
26	Outlet Connector of Pump	1	66	Frame Weldment	1
27	Semicircular Key	1	67	Thick Flat WasherØ12	2
28	Gear Pump Connector	1	68	Hex Bolt M5/16"-1"	4
29	Engine Connector	1	69	Oil Screw ZG1	1
30	Flat Key Ø8x30	1	70	Hydraulic Hose 700	1
31	Bushing Ø25x30	1	71	Hydraulic Hose 850	1
32	Gear Pump Stand	1	72	Antiskid Plate 2	1
33	Gear Pump	1	73	Antiskid Plate 1	1
34	Clamp	4	74	Rivet 4x15	12
35	Gear Pump Oil Pipe 500	1	75	Half-round Screw M5x10	12
36	Wheel Frame Connector Tube (Left)	1	76	Switch Wire for Engine	1
37	50mm Coupler	1	77	Control Valve	1
38	Hex Bolt M12x80	2	78	Outtrigger	2
39	Flat Washer Ø12	4	79	Connector of Valve	7
40	Nylon Lock Nut M12	3	80	Outlet Connector of Valve	1

PART#	DESCRIPTION	QTY	PART#	DESCRIPTION	QTY
81	Hex Bolt M10x30	3	102	Hydraulic Hose 1700	1
82	Oil Cup M6	3	103	Safety Chain	2
83	Axis Pin of Swivel Bracket	1	104	Inlet Connector of Valve	2
84	Cotter Pin 4x60	3	105	Coupling Guard	1
85	Long Pin Ø30x170	2	106	Screw M6x10	1
86	Axis Pin of Swivel Arm Ø48x185	2	107	Hex Bolt M12X90	1
87	Swivel Bracket Weldment	1	108	Flat Washer Ø20	2
88	Long Arm Weldment	1	109	Hex Bolt M5x10	4
89	Fixed Pin Ø19x50	1	110	Block	4
90	Bucket	1	111	Hex Bolt M10x35	4
91	Long Pin Ø30x210	2	112	Plug Screw	1
92	Short Pin Ø30x200	1	113	Washer Ø38	2
93	Bucket Linkage	1	114	Flat Washer Ø24	13
94	Arm Linkage I	1	115	Angle Connector of Swivel cylinder III	2
95	Arm Linkage II	1	116	Oil Plug	1
96	Short Arm Weldment	1	117	Hex Bolt M8x20	4
97	Pin of Bucket Ø30x212	2	118	Spring of seat	4
98	Angle Connector of Cylinder II	1	119	Nylon Lock Nut M6	4
99	Hydraulic Hose 2850	1			
100	Hydraulic Hose 2550	1			
101	Hydraulic Hose 2100	1			